

Remote Control Unit

SAFLOK's™ remote control unit (RCU) is a stand-alone electronic keycard reader designed to work with a variety of exit device applications. The reader offers the widest possible range of security and convenience. Robust, reliable and durable, the RCU is compatible with perimeter door exit devices, entry doors requiring "after-hours" admission, health clubs, spas and banquet facilities. The RCU is a Messenger™-compliant device and can be easily integrated as part of a System 6000™ design.



Remote Control Unit (RCU)

When using the RCU to control perimeter security, keycards can be programmed to allow access to select hotel employees and guests with valid keycards. The units remain locked during specific time periods and can be put into passage mode to enable all valid personnel and current residents/guests unrestricted access. As a standard feature, the RCU is multi-technology enabled.

Measuring 4.05" x 3.05" x 3.01", the RCU's reduced size is further enhanced with LED lights flush-mounted around the insertion reader slot to indicate entry or denied access. Small, lightweight and durable, the unit leaves a minimal footprint making it an ideal fit for even the most restricted spaces. Its applications include:

- Parking arms
- Entry doors
- Pool gates
- Meeting rooms
- Fitness centers
- Concierge

Specifications

Voltage: 12-24 AC/DC

Outside Dimensions: 4.05" (w) x 3.05" (h) x 3.01" (l)

Finish: Dark mahogany

Features

- Auditable entries/attempts
- Reads smart, memory and magnetic stripe keycards
- RCU switch works with electrified locking devices
- Controls electric strikes and magnetic latches up to 24 volts AC/DC
- Auto latch/unlatch feature eliminates need for manual dogging
- SPDT 5A@30VDC relay with common, normally open and normally closed contact
- Messenger-compliant device
- Surface-mounted and flush-mounted options available
- Other finishes available at an upcharge

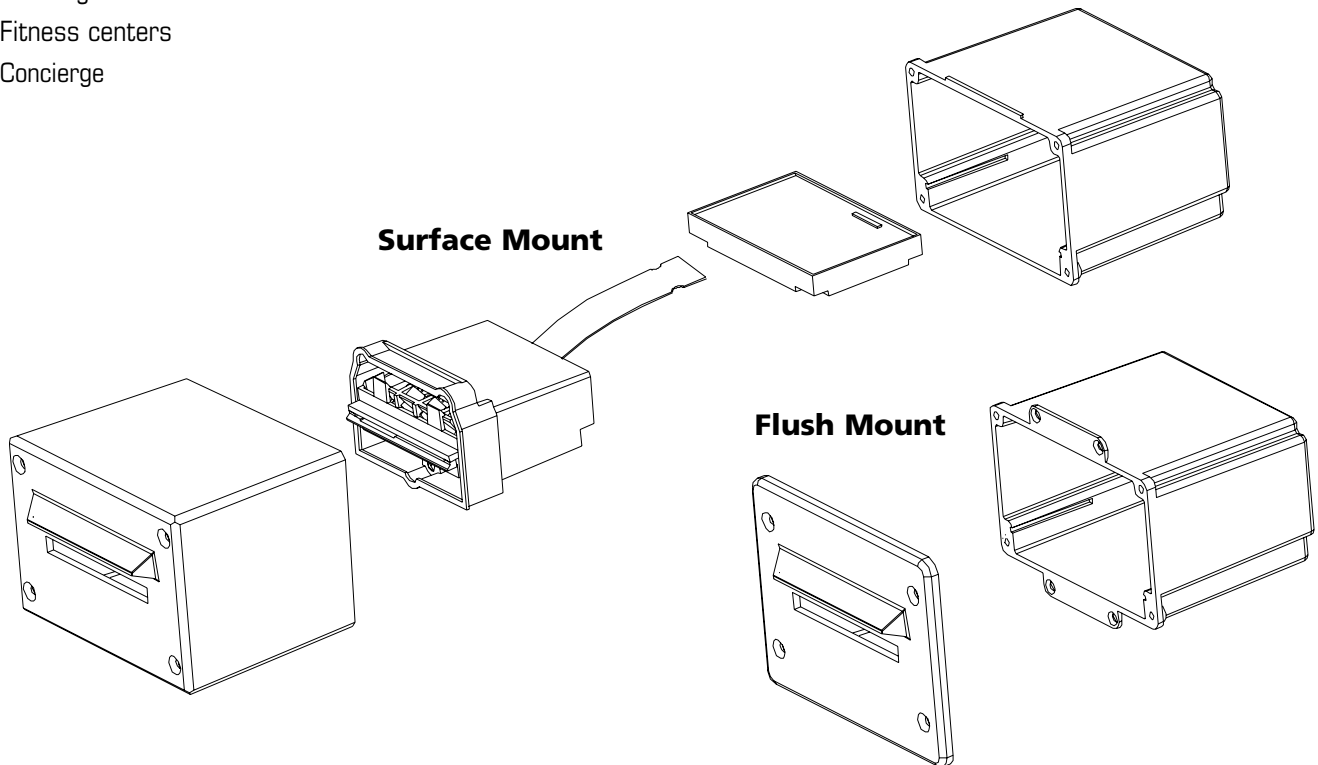

Saflok
A Member of the Kaba Group

For worldwide office locations and contact information, visit us at www.saflok.com.

USA • Canada

Phone: **877.272.3565**

Europe • Middle East • Africa

Phone: **33.1.30.13.04.04**

Asia

Phone: **86.10.5861.3561**

Manufactured under one or more of the following patents:

U.S.: 4,177,657; 4,411,144; 4,534,194; 4,890,870; 5,198,643; 5,477,041; 5,820,177; 5,986,564; 7,051,561; D494,841; D501,131; D512,899; D519,021; D531,629; D533,009; D533,047; D533,762; D533,763; D535,629 CANADA: 1,252,854; 1,298,902
U.K. 2,010,375

Other U.S. and foreign patents pending

SAFLOK reserves the right to modify the characteristics and features of all products in this publication.
©2008 SAFLOK, all rights reserved.